

Min. Ø1/4" x 2" lg. zinc plated carbon steel,
concrete anchor, spaced @ 24" O.C.

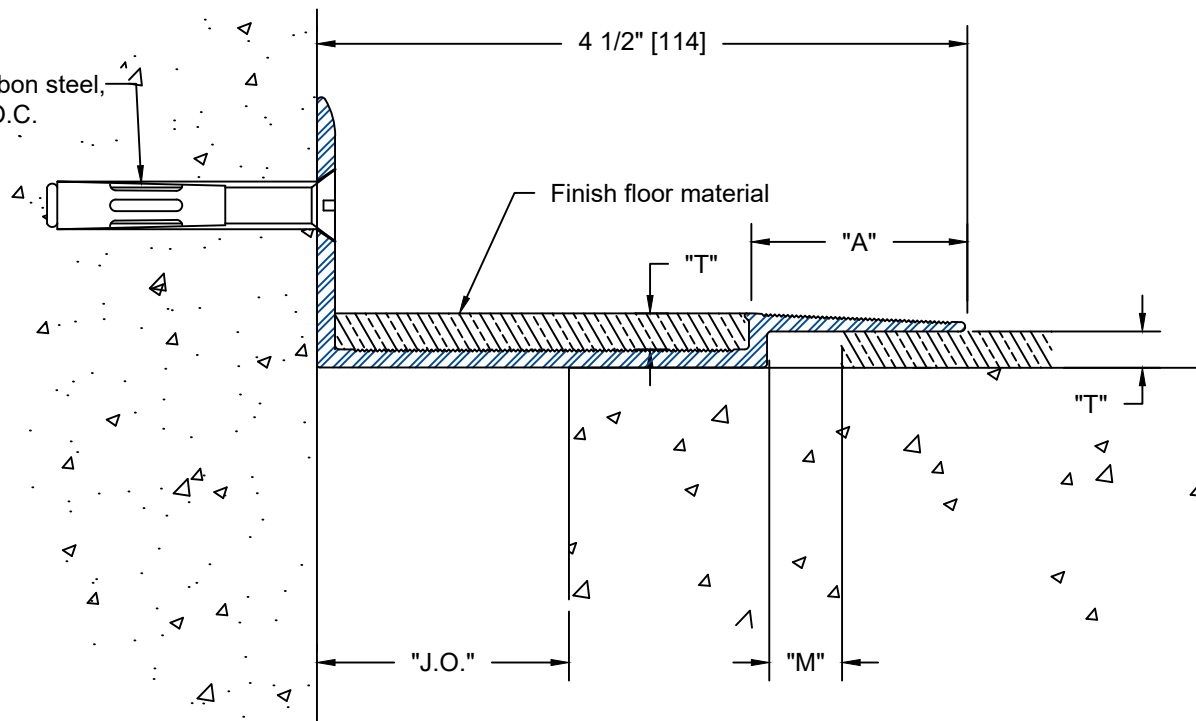

Typical Section
Floor to Floor Condition

Profile Selection Chart <small>Bold numbers indicate inches Light numbers indicate millimeters</small>							
Model	System Dimensions			Joint Opening and Horizontal Movement			
	Exposed "A"	Floor Covering Thickness "T"	"M"	"J.O." Install	"J.O." Minimum	"J.O." Maximum	Total Movement
FJS-200.125C	1 1/2 38	1/8 3	1/2 13	2 51	1 1/2 38	2 1/2 64	1 25
FJS-200.250C	1 1/2 38	1/4 6	1/2 13	2 51	1 1/2 38	2 1/2 64	1 25
FJS-200.375C	1 1/2 38	3/8 10	1/2 13	2 51	1 1/2 38	2 1/2 64	1 25

Note: J.O. minimum and maximum values are after thermal movement occurs.

PROJECT NAME: -

PROJECT LOCATION: -

DRAWING DESCRIPTION:

Wabo®FastFloor

DATE: 01/15/2021

MODEL: FJS-C



Watson Bowman Acme
95 Pineview Drive Amherst, NY 14228
phone: (716) 691-7566 fax: (716) 691-9239
www.watsonbowmanacme.com

A brand of **MBC GROUP**

Information provided herein, including but not limited to, any drawing, design, photograph, graphic, or statement(s) ("Materials") are proprietary and the property of Watson Bowman Acme Corporation ("Company"). Reproduction, translation, or reduction to any electronic medium or machine readable form, in whole or part, is strictly prohibited, except for the express purpose for which it has been furnished, without prior written consent of Company. All Materials contained herein are provided by Company for information purposes only. Company reserves the right to amend or withdraw any information contained in the Materials without notice. All technical or other advice by Company, whether verbal or written, concerning products, or the use of products in specific situations ("Advice") is given by Company and is used at the Users own risk.

REVISION NO:

-

SHEET NO:

2

DRAWING NO:

C20419