

Wabo® StripSeal Type "M"
Cast in Place Condition

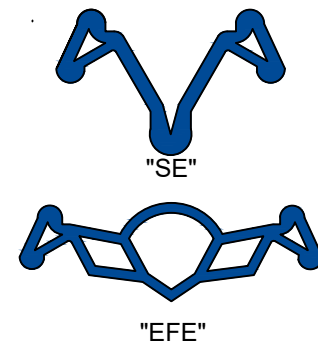

| Seal Dimension Table | | | | | | | | |
|----------------------|----------------|-----|-----------------|-------------|---------|---------|--------------------|----|
| Model Number | Total Movement | | Joint Width "A" | | | | Min. Install Width | |
| | inches | mm | Min. inches | Max. inches | Min. mm | Max. mm | inches | mm |
| SE-300 | 3.000 | 76 | 0 | 0 | 3.000 | 76 | 1.500 | 38 |
| SE-400 | 4.000 | 102 | 0 | 0 | 4.000 | 102 | 1.500 | 38 |
| SE-500 | 5.000 | 127 | 0 | 0 | 5.000 | 127 | 2.000 | 51 |
| EFE-400 | 4.000 | 102 | 0.500 | 13 | 4.500 | 114 | 2.500 | 64 |

Consult your WBA Representative for factory molded horizontal changes, severe skews or joint intersections

Design Features

- Rugged design accodating HS-20 loading
- Extrusion cavity mechanically locks all seal profiles for watertight application
- System can be cast into the concrete slab
- Accommodates multi-directional movements
- Custom designs engineered for unique projects

PROJECT NAME: _____

PROJECT LOCATION: _____

DRAWING DESCRIPTION:
Wabo®StripSeal Type "M"

DATE: 5/2021 MODEL: Type "M"



Watson Bowman Acme
95 Pineview Drive Amherst, NY 14228
phone: (716) 691-7566 fax: (716) 691-9239
www.watsonbowmanacme.com

A brand of
MBCC GROUP

Information provided herein, including but not limited to, any drawing, design, photograph, graphic, or statement(s) ("Materials") are proprietary and the property of Watson Bowman Acme Corporation ("Company"). Reproduction, translation, or reduction to any electronic medium or machine readable form, in whole or part, is strictly prohibited, except for the express purpose for which it has been furnished, without prior written consent of Company. All Materials contained herein are provided by Company for information purposes only. Company reserves the right to amend or withdraw any information contained in the Materials without notice. All technical or other advice by Company, whether verbal or written, concerning products, or the use of products in specific situations ("Advice") is given by Company and is used at the Users own risk.

REVISION NO: _____

SHEET NO: 1

DRAWING NO: C20519

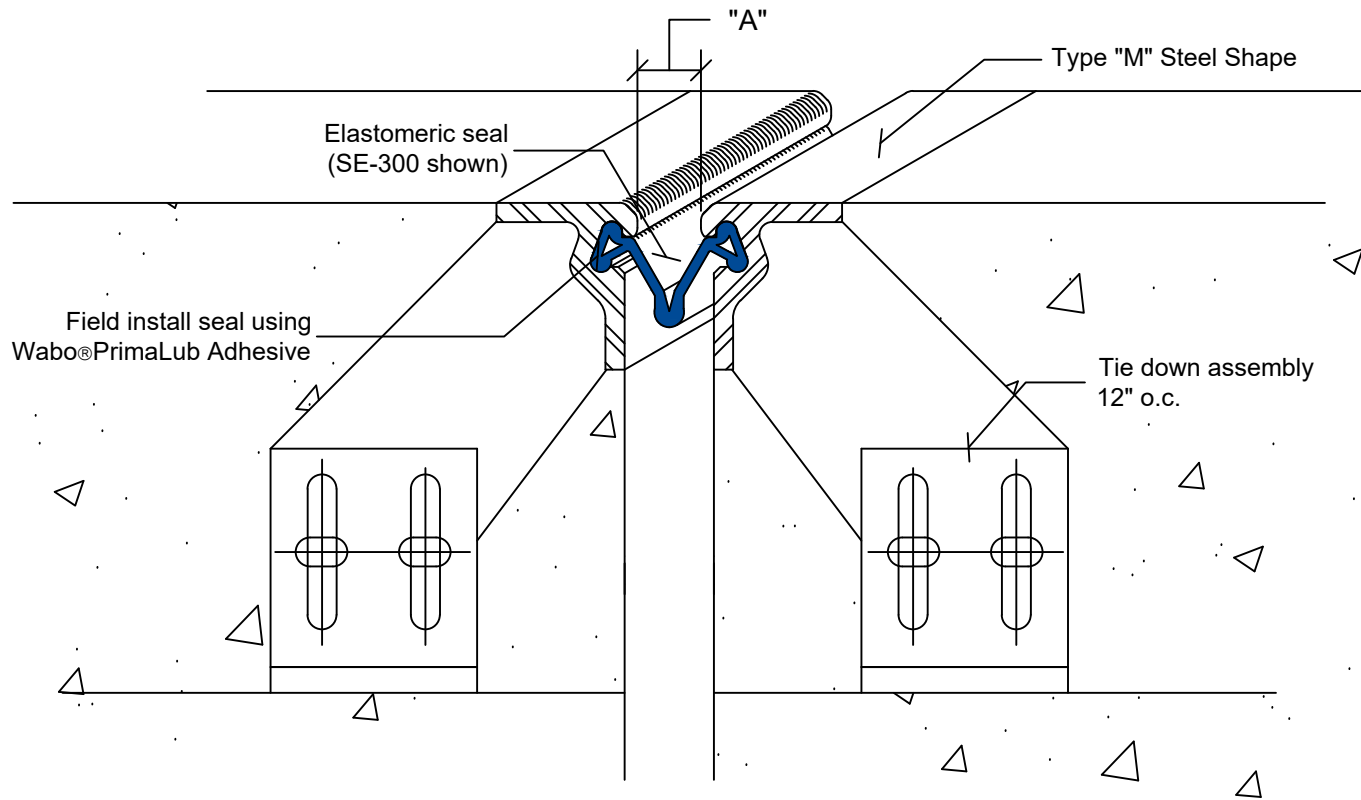

Wabo®StripSeal Type "M"
Tie Down Condition

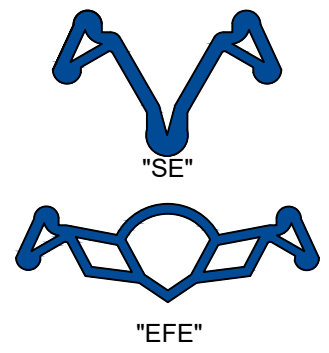

Design Features

- Rugged design accodating HS-20 loading
- Extrusion cavity mechanically locks all seal profiles for watertight application
- Accommodates multi-directional movements

| Model Number | Total Movement | | Joint Width "A" | | | | Min. Install Width | |
|--------------|----------------|-----|-----------------|----|--------|-----|--------------------|----|
| | inches | mm | Min. | | Max. | | inches | mm |
| | | | inches | mm | inches | mm | | |
| SE-300 | 3.000 | 76 | 0 | 0 | 3.000 | 76 | 1.500 | 38 |
| SE-400 | 4.000 | 102 | 0 | 0 | 4.000 | 102 | 1.500 | 38 |
| SE-500 | 5.000 | 127 | 0 | 0 | 5.000 | 127 | 2.000 | 51 |
| EFE-400 | 4.000 | 102 | 0.500 | 13 | 4.500 | 114 | 2.500 | 64 |

Consult your WBA Representative for factory molded horizontal changes, severe skews or joint intersections

PROJECT NAME: _____

PROJECT LOCATION: _____

DRAWING DESCRIPTION:
Wabo®StripSeal

DATE: 05/2021 MODEL: Type "M"



Watson Bowman Acme
95 Pineview Drive Amherst, NY 14228
phone: (716) 691-7566 fax: (716) 691-9239
www.watsonbowmanacme.com

A brand of
MBCC GROUP

Information provided herein, including but not limited to, any drawing, design, photograph, graphic, or statement(s) ("Materials") are proprietary and the property of Watson Bowman Acme Corporation ("Company"). Reproduction, translation, or reduction to any electronic medium or machine readable form, in whole or part, is strictly prohibited, except for the express purpose for which it has been furnished, without prior written consent of Company. All Materials contained herein are provided by Company for information purposes only. Company reserves the right to amend or withdraw any information contained in the Materials without notice. All technical or other advice by Company, whether verbal or written, concerning products, or the use of products in specific situations ("Advice") is given by Company and is used at the Users own risk.

REVISION NO: _____

SHEET NO: 2

DRAWING NO: C20519

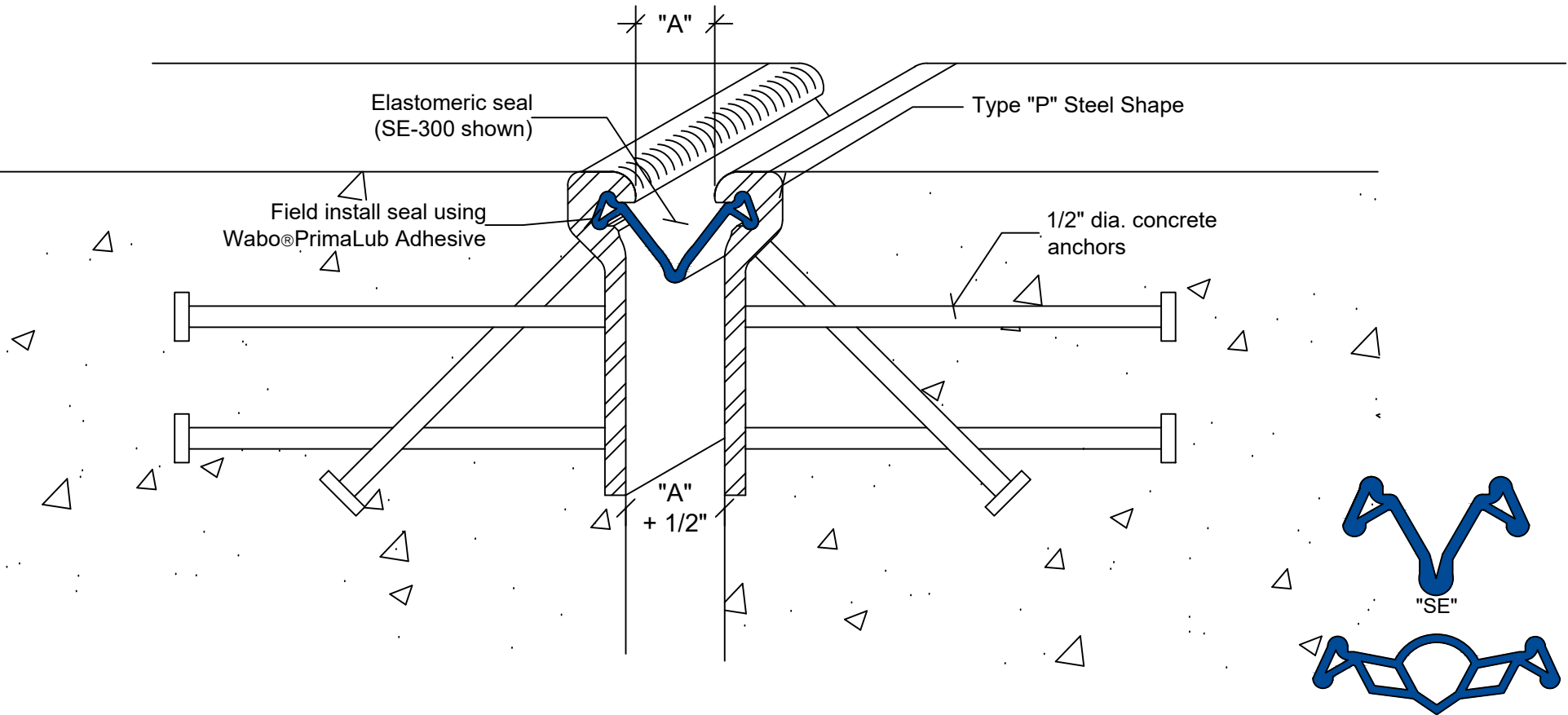

Wabo®StripSeal Type "P"

Cast In Place Condition

Design Features

- Rugged design accodating HS-20 loading
- Extrusion cavity mechanically locks all seal profiles for watertight application
- Accommodates multi-directional movements

| Seal Dimension Table | | | | | | | | |
|----------------------|----------------|-----|-----------------|----|-------------|-----|--------------------|----|
| Model Number | Total Movement | | Joint Width "A" | | | | Min. Install Width | |
| | inches | mm | Min. inches | mm | Max. inches | mm | inches | mm |
| SE-300 | 3.000 | 76 | 0 | 0 | 3.000 | 76 | 1.500 | 38 |
| SE-400 | 4.000 | 102 | 0 | 0 | 4.000 | 102 | 1.500 | 38 |
| SE-500 | 5.000 | 127 | 0 | 0 | 5.000 | 127 | 2.000 | 51 |
| EFE-400 | 4.000 | 102 | 0.500 | 13 | 4.500 | 114 | 2.500 | 64 |

Consult your WBA Representative for factory molded horizontal changes, severe skews or joint intersections

PROJECT NAME: -

PROJECT LOCATION: -

DRAWING DESCRIPTION:

Wabo®StripSeal

DATE: 05/2021

MODEL: Type "P"



Watson Bowman Acme
 95 Pineview Drive Amherst, NY 14228
 phone: (716) 691-7566 fax: (716) 691-9239
 www.watsonbowmanacme.com

A brand of
MBCC GROUP

Information provided herein, including but not limited to, any drawing, design, photograph, graphic, or statement(s) ("Materials") are proprietary and the property of Watson Bowman Acme Corporation ("Company"). Reproduction, translation, or reduction to any electronic medium or machine readable form, in whole or part, is strictly prohibited, except for the express purpose for which it has been furnished, without prior written consent of Company. All Materials contained herein are provided by Company for information purposes only. Company reserves the right to amend or withdraw any information contained in the Materials without notice. All technical or other advice by Company, whether verbal or written, concerning products, or the use of products in specific situations ("Advice") is given by Company and is used at the Users own risk.

REVISION NO:

SHEET NO:

3

DRAWING NO:

C20519

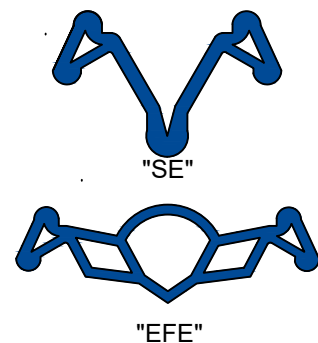
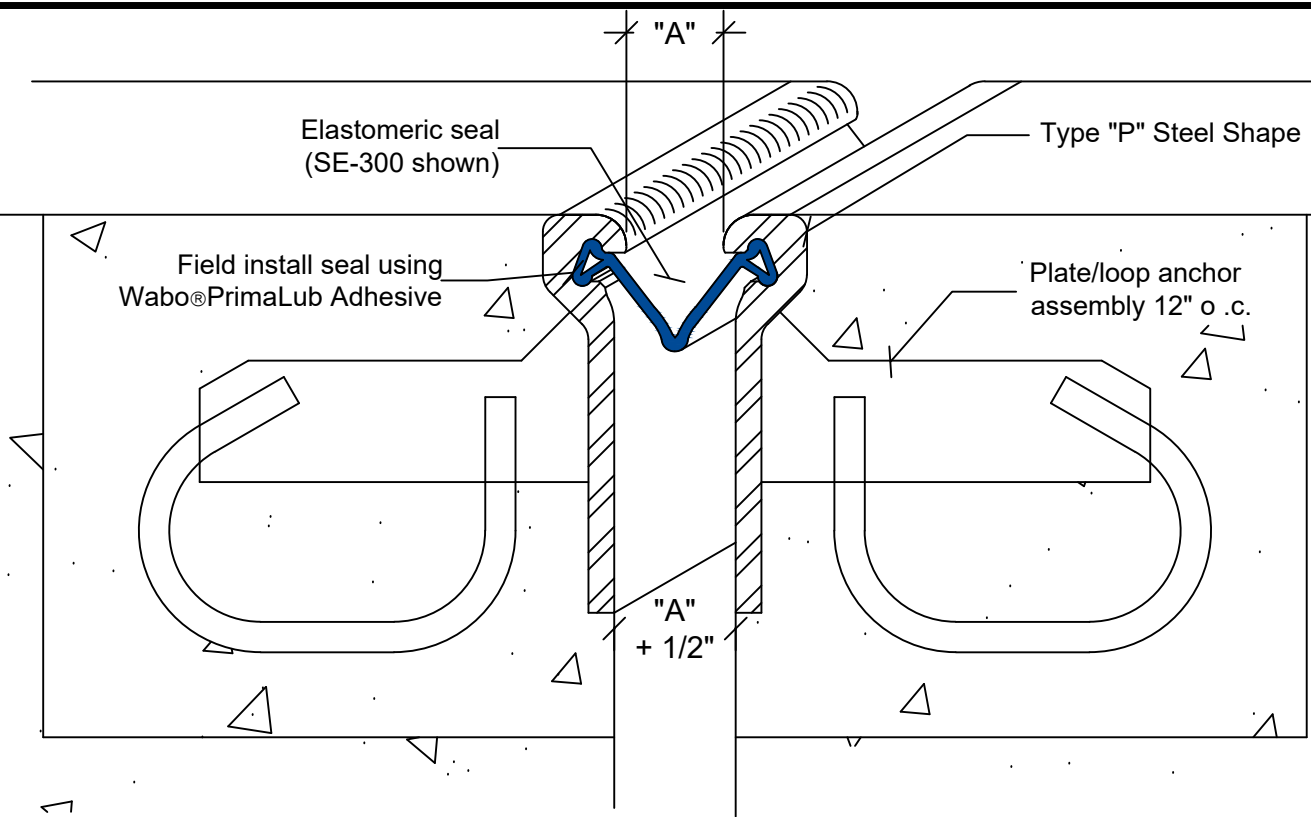

Wabo®StripSeal Type "P"

Cast In Place Condition

Design Features

- Rugged design accodating HS-20 loading
- Extrusion cavity mechanically locks all seal profiles for watertight application
- Accommodates multi-directional movements

| Model Number | Total Movement | | Joint Width "A" | | | | Min. Install Width | |
|--------------|----------------|-----|-----------------|----|--------|-----|--------------------|----|
| | | | Min. | | Max. | | | |
| | inches | mm | inches | mm | inches | mm | inches | mm |
| SE-300 | 3.000 | 76 | 0 | 0 | 3.000 | 76 | 1.500 | 38 |
| SE-400 | 4.000 | 102 | 0 | 0 | 4.000 | 102 | 1.500 | 38 |
| SE-500 | 5.000 | 127 | 0 | 0 | 5.000 | 127 | 2.000 | 51 |
| EFE-400 | 4.000 | 102 | 0.500 | 13 | 4.500 | 114 | 2.500 | 64 |

Consult your WBA Representative for factory molded horizontal changes, severe skews or joint intersections

PROJECT NAME: _____

PROJECT LOCATION: _____

DRAWING DESCRIPTION:
Wabo®StripSeal

DATE: 05/2021 MODEL: Type "P"



Watson Bowman Acme
95 Pineview Drive Amherst, NY 14228
phone: (716) 691-7566 fax: (716) 691-9239
www.watsonbowmanacme.com

A brand of
MBCC GROUP

Information provided herein, including but not limited to, any drawing, design, photograph, graphic, or statement(s) ("Materials") are proprietary and the property of Watson Bowman Acme Corporation ("Company"). Reproduction, translation, or reduction to any electronic medium or machine readable form, in whole or part, is strictly prohibited, except for the express purpose for which it has been furnished, without prior written consent of Company. All Materials contained herein are provided by Company for information purposes only. Company reserves the right to amend or withdraw any information contained in the Materials without notice. All technical or other advice by Company, whether verbal or written, concerning products, or the use of products in specific situations ("Advice") is given by Company and is used at the Users own risk.

REVISION NO: _____

SHEET NO: 4

DRAWING NO: C20519

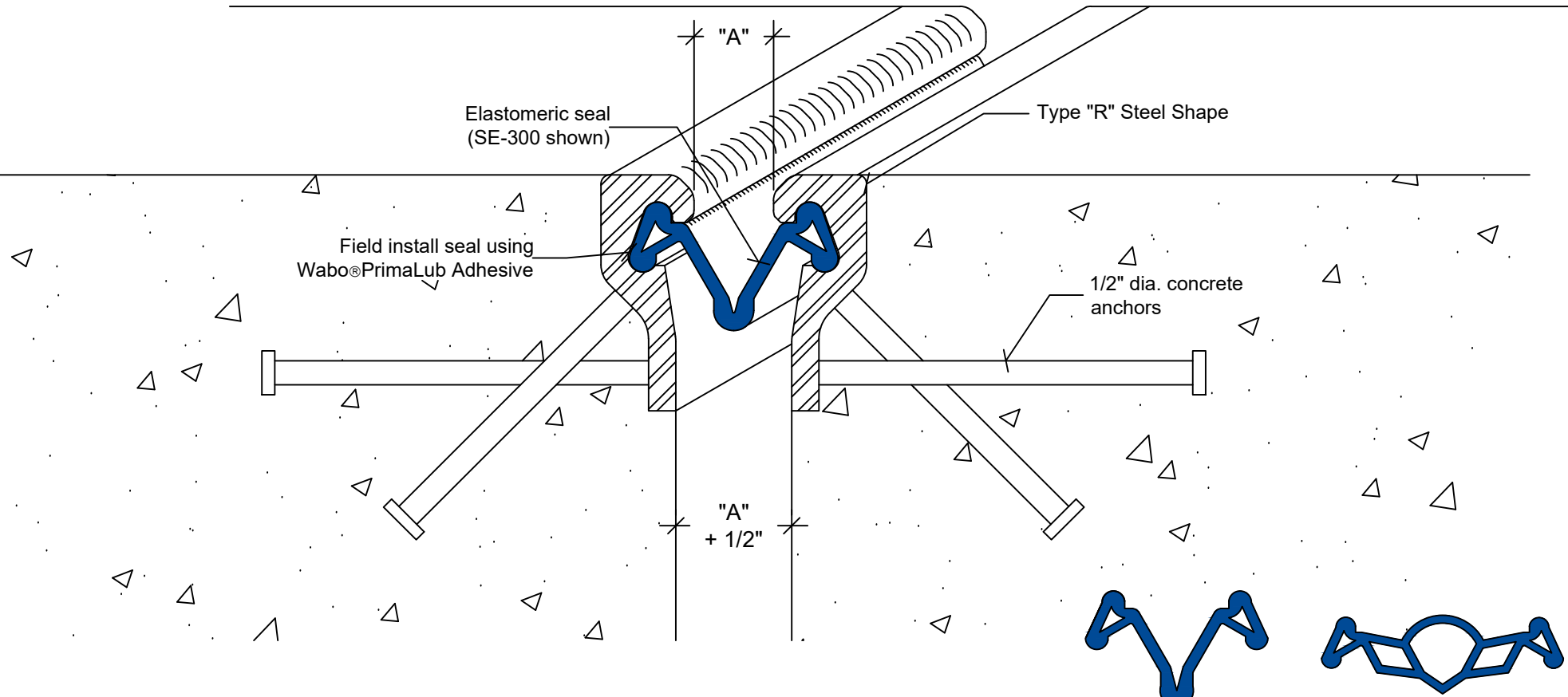

Wabo®StripSeal Type "R"

Cast In Place Condition

Design Features

- Rugged design accommodating HS-20 loading
- Extrusion cavity mechanically locks all seal profiles for watertight application
- Accommodates multi-directional movements

| Seal Dimension Table | | | | | | | | |
|----------------------|----------------|-----|-----------------|----|-------|-----|--------------------|----|
| Model Number | Total Movement | | Joint Width "A" | | | | Min. Install Width | |
| | inches | mm | Min. | mm | Max. | mm | inches | mm |
| SE-300 | 3.000 | 76 | 0 | 0 | 3.000 | 76 | 1.500 | 38 |
| SE-400 | 4.000 | 102 | 0 | 0 | 4.000 | 102 | 1.500 | 38 |
| SE-500 | 5.000 | 127 | 0 | 0 | 5.000 | 127 | 2.000 | 51 |
| EFE-400 | 4.000 | 102 | 0.500 | 13 | 4.500 | 114 | 2.500 | 64 |

Consult your WBA Representative for factory molded horizontal changes, severe skews or joint intersections

PROJECT NAME: _____

PROJECT LOCATION: _____

DRAWING DESCRIPTION:
Wabo®StripSeal

DATE: 5/2021 MODEL: Type "R"



Watson Bowman Acme
95 Pineview Drive Amherst, NY 14228
phone: (716) 691-7566 fax: (716) 691-9239
www.watsonbowmanacme.com

A brand of
MBCC GROUP

Information provided herein, including but not limited to, any drawing, design, photograph, graphic, or statement(s) ("Materials") are proprietary and the property of Watson Bowman Acme Corporation ("Company"). Reproduction, translation, or reduction to any electronic medium or machine readable form, in whole or part, is strictly prohibited, except for the express purpose for which it has been furnished, without prior written consent of Company. All Materials contained herein are provided by Company for information purposes only. Company reserves the right to amend or withdraw any information contained in the Materials without notice. All technical or other advice by Company, whether verbal or written, concerning products, or the use of products in specific situations ("Advice") is given by Company and is used at the Users own risk.

REVISION NO: _____

SHEET NO: 5

DRAWING NO: C20519

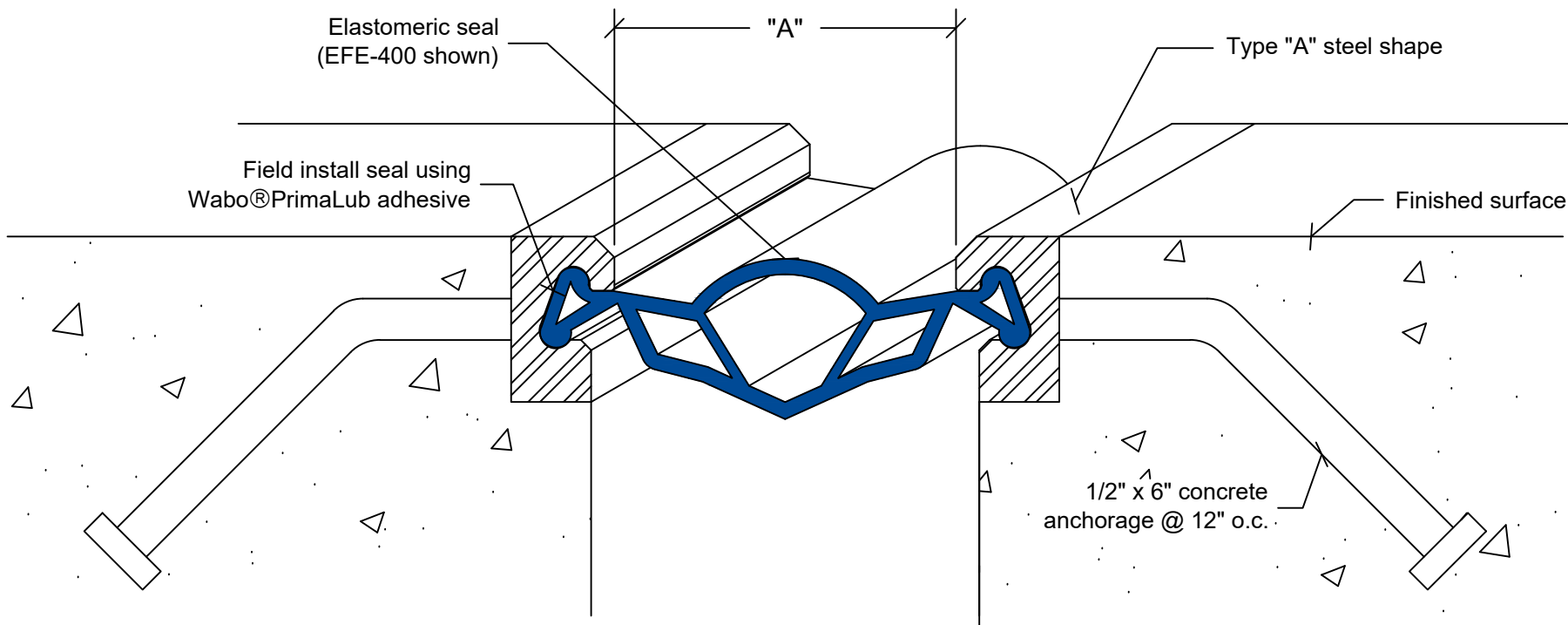

Wabo®StripSeal Type "A"

Cast in Place Condition

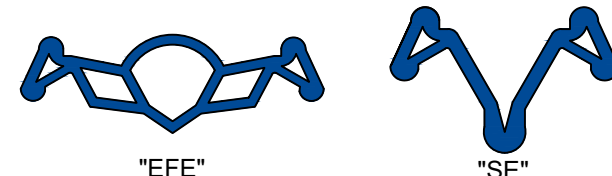

Design Features

- Rugged design accodating HS-20 loading
- Extrusion cavity mechanically locks all seal profiles for watertight application
- System can be cast into the concrete slab
- Accommodates multi-directional movements
- Custom designs engineered for unique projects

| Model Number | Seal Dimension Table | | | | | | | |
|--------------|----------------------|-----|-----------------|------|-------|------|--------------------|----|
| | Total Movement | | Joint Width "A" | | | | Min. Install Width | |
| | inches | mm | Min. | Max. | Min. | Max. | inches | mm |
| SE-300 | 3.000 | 76 | 0 | 0 | 3.000 | 76 | 1.500 | 38 |
| SE-400 | 4.000 | 102 | 0 | 0 | 4.000 | 102 | 1.500 | 38 |
| SE-500 | 5.000 | 127 | 0 | 0 | 5.000 | 127 | 2.000 | 51 |
| EFE-400 | 4.000 | 102 | 0.500 | 13 | 4.500 | 114 | 2.500 | 64 |

Consult your WBA Representative for factory molded horizontal changes, severe skews or joint intersections

PROJECT NAME: -

PROJECT LOCATION: -

DRAWING DESCRIPTION:

Wabo®StripSeal

DATE: 05/2021

MODEL: Type "A"



Watson Bowman Acme
95 Pineview Drive Amherst, NY 14228
phone: (716) 691-7566 fax: (716) 691-9239
www.watsonbowmanacme.com

A brand of
MBCC GROUP

Information provided herein, including but not limited to, any drawing, design, photograph, graphic, or statement(s) ("Materials") are proprietary and the property of Watson Bowman Acme Corporation ("Company"). Reproduction, translation, or reduction to any electronic medium or machine readable form, in whole or part, is strictly prohibited, except for the express purpose for which it has been furnished, without prior written consent of Company. All Materials contained herein are provided by Company for information purposes only. Company reserves the right to amend or withdraw any information contained in the Materials without notice. All technical or other advice by Company, whether verbal or written, concerning products, or the use of products in specific situations ("Advice") is given by Company and is used at the Users own risk.

REVISION NO:

SHEET NO:

5

DRAWING NO:

C20519

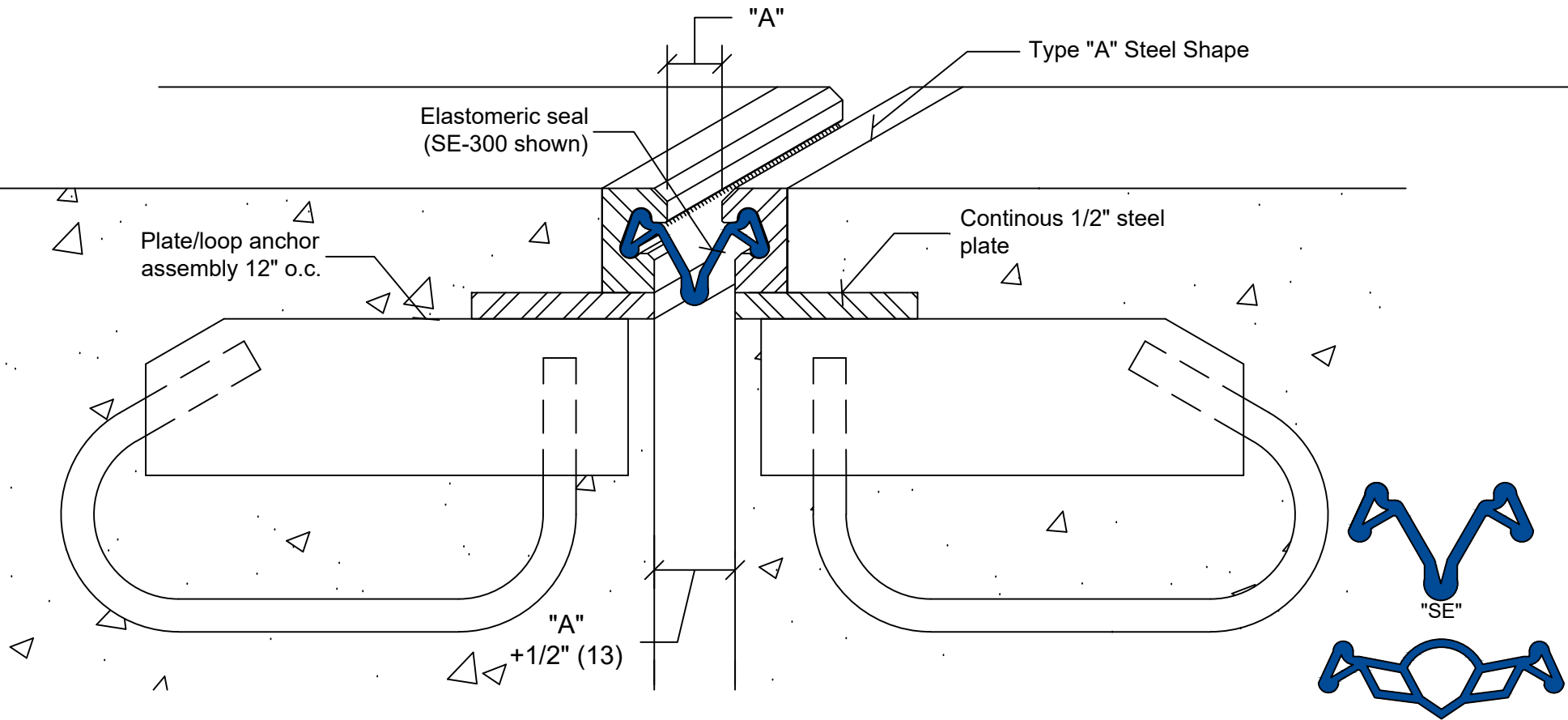

Wabo® StripSeal Type "A" Modified

Cast in Place Condition

Design Features

- Rugged design accodating HS-20 loading
- Extrusion cavity mechanically locks all seal profiles for watertight application
- System can be cast into the concrete slab
- Accommodates multi-directional movements
- Custom designs engineered for unique projects

| Model Number | Seal Dimension Table | | | | | | | |
|--------------|----------------------|-----|-----------------|----|-------------|-----|--------------------|----|
| | Total Movement | | Joint Width "A" | | | | Min. Install Width | |
| | inches | mm | Min. inches | mm | Max. inches | mm | inches | mm |
| SE-300 | 3.000 | 76 | 0 | 0 | 3.000 | 76 | 1.500 | 38 |
| SE-400 | 4.000 | 102 | 0 | 0 | 4.000 | 102 | 1.500 | 38 |
| SE-500 | 5.000 | 127 | 0 | 0 | 5.000 | 127 | 2.000 | 51 |
| EFE-400 | 4.000 | 102 | 0.500 | 13 | 4.500 | 114 | 2.500 | 64 |

Consult your WBA Representative for factory molded horizontal changes, severe skews or joint intersections

PROJECT NAME: -

PROJECT LOCATION: -

DRAWING DESCRIPTION:

Wabo® StripSeal

DATE: 05/2021

MODEL: Type "A"



Watson Bowman Acme
 95 Pineview Drive Amherst, NY 14228
 phone: (716) 691-7566 fax: (716) 691-9239
 www.watsonbowmanacme.com

A brand of
MBCC GROUP

Information provided herein, including but not limited to, any drawing, design, photograph, graphic, or statement(s) ("Materials") are proprietary and the property of Watson Bowman Acme Corporation ("Company"). Reproduction, translation, or reduction to any electronic medium or machine readable form, in whole or part, is strictly prohibited, except for the express purpose for which it has been furnished, without prior written consent of Company. All Materials contained herein are provided by Company for information purposes only. Company reserves the right to amend or withdraw any information contained in the Materials without notice. All technical or other advice by Company, whether verbal or written, concerning products, or the use of products in specific situations ("Advice") is given by Company and is used at the Users own risk.

REVISION NO:

-

SHEET NO:

7

DRAWING NO:

C20519

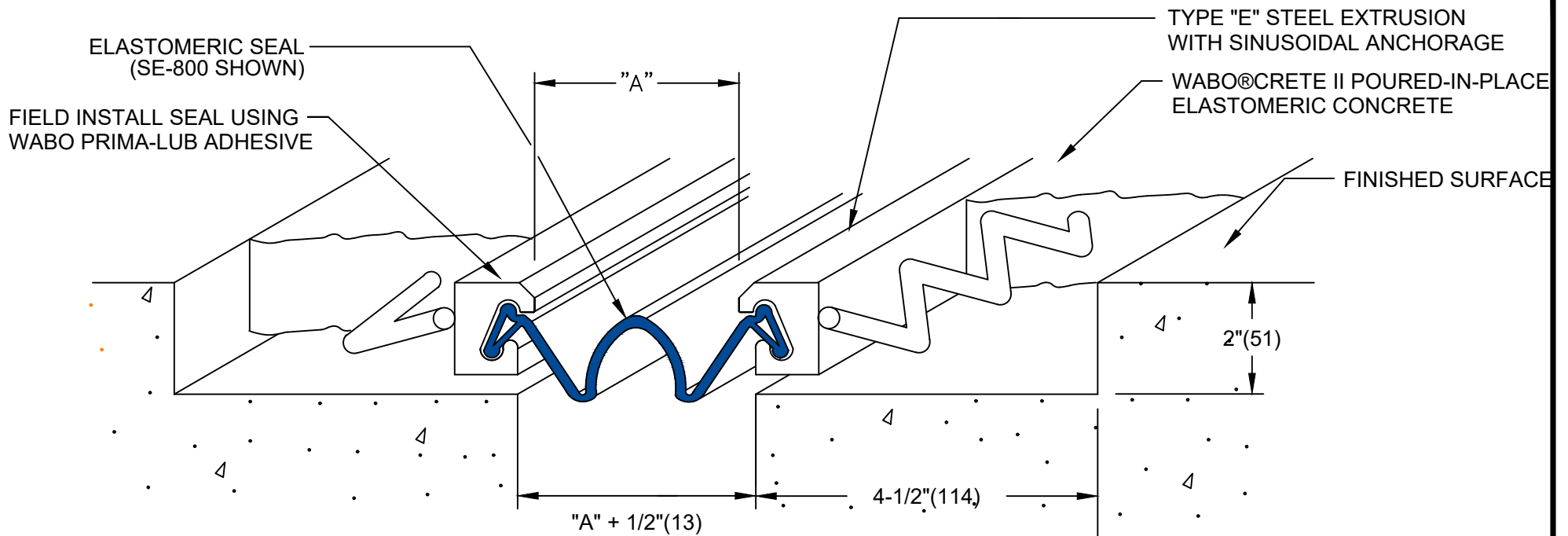

Wabo®CreteStripSeal (Model:SSS) DETAIL
 SLAB TO SLAB CONDITION
 NOT TO SCALE

Design Features

- Rugged design accommodating HS-20 loading
- Extrusion cavity mechanically locks all seal profiles for watertight application
- System can be cast into the concrete slab
- Accommodates multi-directional movements
- Custom designs engineered for unique projects

() - DENOTES MILLIMETERS

| DIMENSION CHART | | | | | |
|-----------------|--------|-----------|-------------|-------------|----------------|
| PROFILE | MODEL | "A" @ MIN | "A" @ MID | "A" @ MAX | Total Movement |
| | SE-800 | 1/2"(13) | 4-1/2"(114) | 8-1/2"(216) | 8"(203) |

PROJECT NAME: -

PROJECT LOCATION: -

DRAWING DESCRIPTION:

Wabo®StripSeal

DATE: 05/2021

MODEL: Type "E"



Watson Bowman Acme
 95 Pineview Drive Amherst, NY 14228
 phone: (716) 691-7566 fax: (716) 691-9239
 www.watsonbowmanacme.com

A brand of
MBCC GROUP

Information provided herein, including but not limited to, any drawing, design, photograph, graphic, or statement(s) ("Materials") are proprietary and the property of Watson Bowman Acme Corporation ("Company"). Reproduction, translation, or reduction to any electronic medium or machine readable form, in whole or part, is strictly prohibited, except for the express purpose for which it has been furnished, without prior written consent of Company. All Materials contained herein are provided by Company for information purposes only. Company reserves the right to amend or withdraw any information contained in the Materials without notice. All technical or other advice by Company, whether verbal or written, concerning products, or the use of products in specific situations ("Advice") is given by Company and is used at the Users own risk.

REVISION NO:

-

SHEET NO:

8

DRAWING NO:

C20519