

# Installation Procedure

Last Updated: May 2021

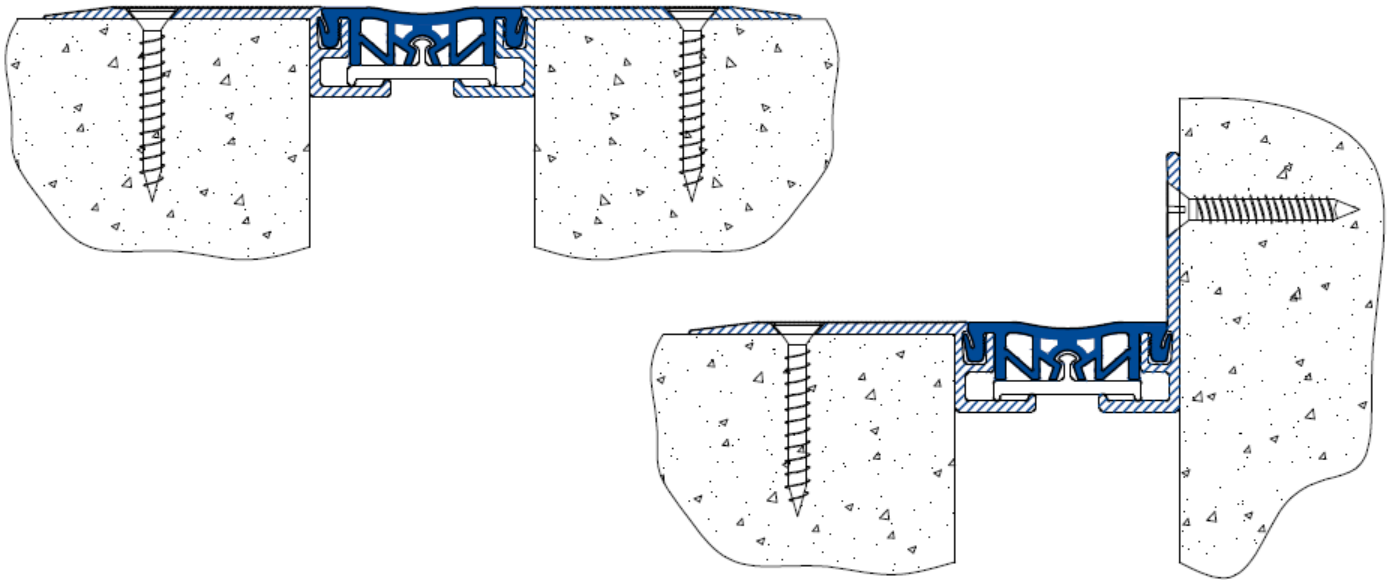

## Wabo®CorridorWrap, “CWFS” & “CWFS-C” Interior Floor Expansion Joint System

The following installation procedure is very important and must be fully understood prior to beginning any work. To ensure proper installation and performance of expansion joint system the following actions must be completed by the installing contractor. Failure to do so will affect product warranty.

- 1) Carefully read and understand installation procedure. Contact WBA's Technical Service Department at (800) 677-4922 for product assistance.
- 2) Inspect all shipments and materials for missing or damaged components and hardware. Contact Customer Service at (800) 677-4922 with WBA's order number and invoice for prompt assistance.
- 3) Inspect substrate or adjacent construction for acceptance before beginning work. Report unacceptable construction to the project manager for scheduled repair work.
- 4) Review WBA shop drawings for project specific detailed information if Engineering services were purchased at time of order.

Information provided herein, including but not limited to, any drawing, design, photograph, graphic, or statement(s) ("Materials") are proprietary and the property of Watson Bowman Acme Corp. ("Company"). Reproduction, translation, or reduction to any electronic medium or machine readable form, in whole or part, is strictly prohibited, except for the express purpose for which it has been furnished, without prior written consent of Company. All Materials contained herein are provided by Company for information purposes only. Company reserves the right to amend or withdraw any information contained in the Materials without notice. All technical or other advice by Company, whether verbal or written, concerning products, or the use of products in specific situations ("Advice") is given by Company and is used at the User's own risk.

# Health & Safety

During the installation of any Watson Bowman Acme product, appropriate personal protective items should be worn at all times, including but not limited to the following:

- Proper work clothing
- Safety glasses
- Safety boots
- Gloves
- Hard hat



Local rules and regulations regarding safe work environments and health should be followed.

# Product Components

The following components are required for the installation of this product:



#12 x 1 3/4" Spax Anchor Part  
Number – **6530** (Floor Anchor Only)

Components below vary in size depending on model of system:

CWFS-100 Floor Mount Aluminum Extrusion P/n - 1604

Center Support Aluminum Extrusion P/n - See Below

Model	"A"	P/N
CWFS-200/200C	1 5/16"	1618
CWFS-300/300C	2 1/16"	1625

\* Wall Mount Aluminum Extrusion P/n - See Below

Model	"B"	P/N
CWFS-200C	23/32"	1616
CWFS-300C	31/32"	1617

\* CWFS-100C Wall Mount Aluminum Extrusion P/n - 1615



~ 241F Adhesive, P/n: **2716**



~ PP Primer for 241F Adhesive, P/n: **2717**

25/32" (Nominal)



CWFS-100

1 25/32" (Nominal)



CWFS-200

2 25/32"



CWFS-300

Model	Part Number			
	Black Seal	White Seal	Beige Seal	Grey Seal
CWFS-100/100C	17501	17504	17503	17502
CWFS-200/200C	17601	17604	17603	17602
CWFS-300/300C	17701	17704	17703	17702

~ Optional components for splice procedures. Place order for required quantities.

\* Components required for corner condition.

# Installation

- 1 Prior to beginning work, installer shall inspect corners of concrete slab for acceptability. For repair (if required), refer to step 2; also, measure joint opening for proper size as called for on WBA shop drawings or CAD detail.

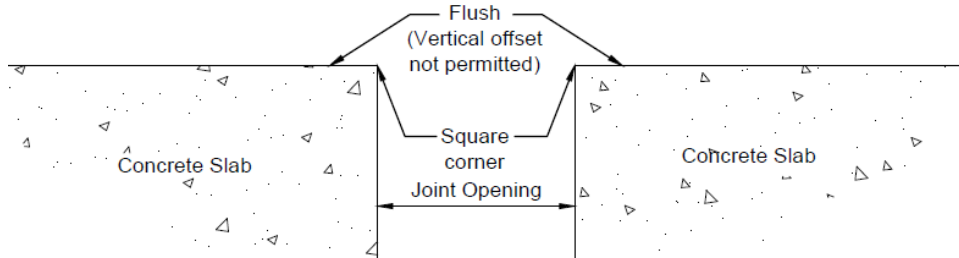

## Corner Condition

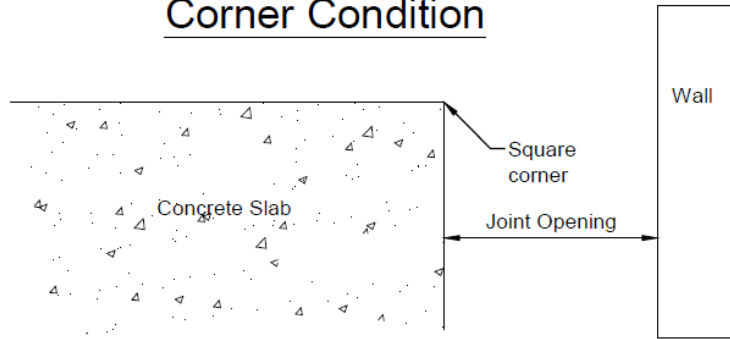

- 2 Utilizing concrete repair materials, repair corner of concrete slab, following manufacturer's written instructions.

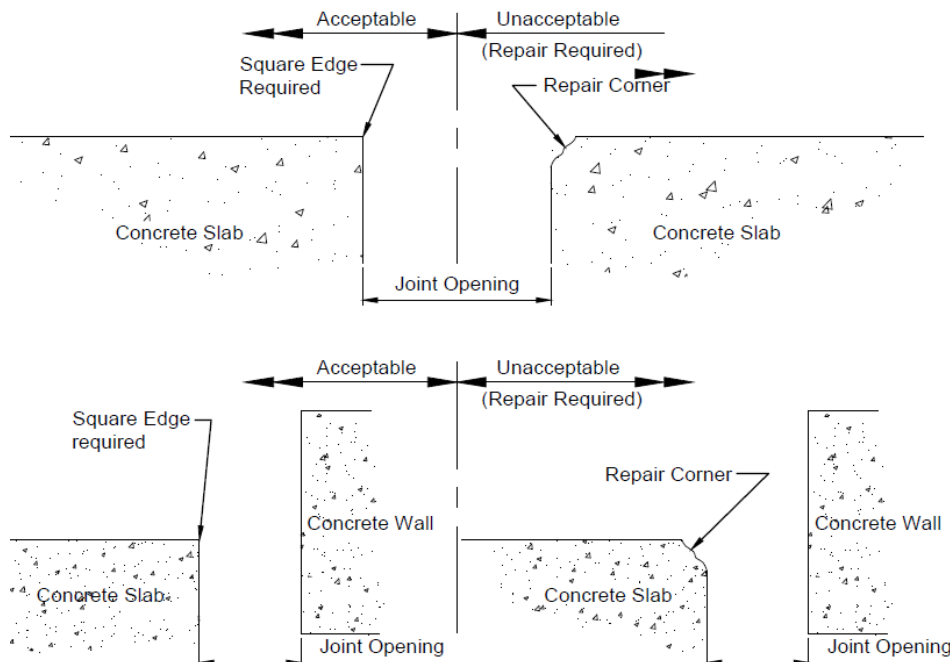

- 3** Mount & secure the aluminum edge members at the expansion joint opening, utilizing the hardware provided.

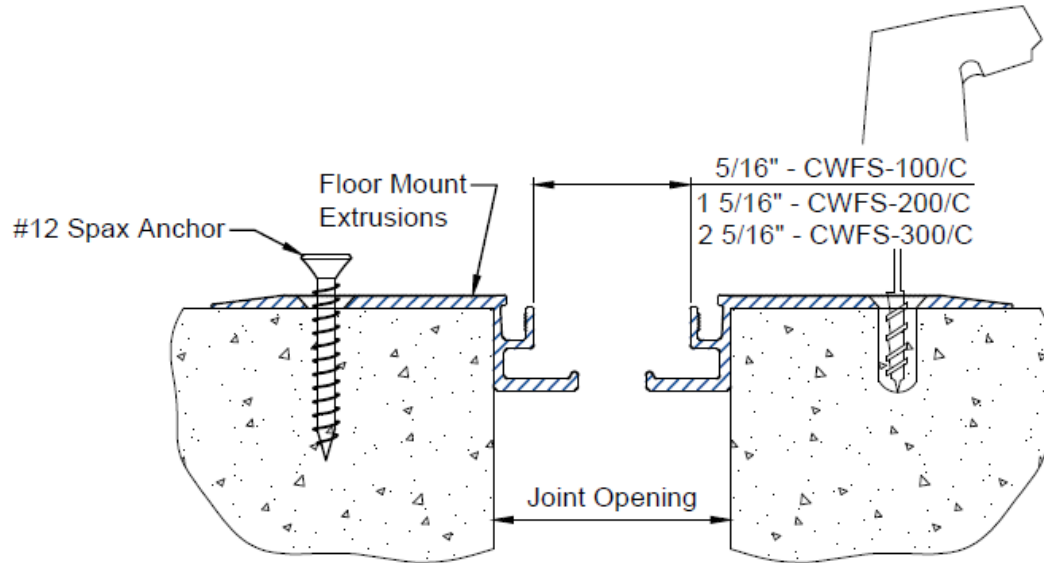

- 3A** For installation of Wall Mount Aluminum Extrusion, utilize a suitable anchor (By Others) spaced at 24" Max. O.C. based upon the wall construction.  
**Note:** Wall Mount Extrusion is not pre-drilled by the manufacturer.

### Corner Condition

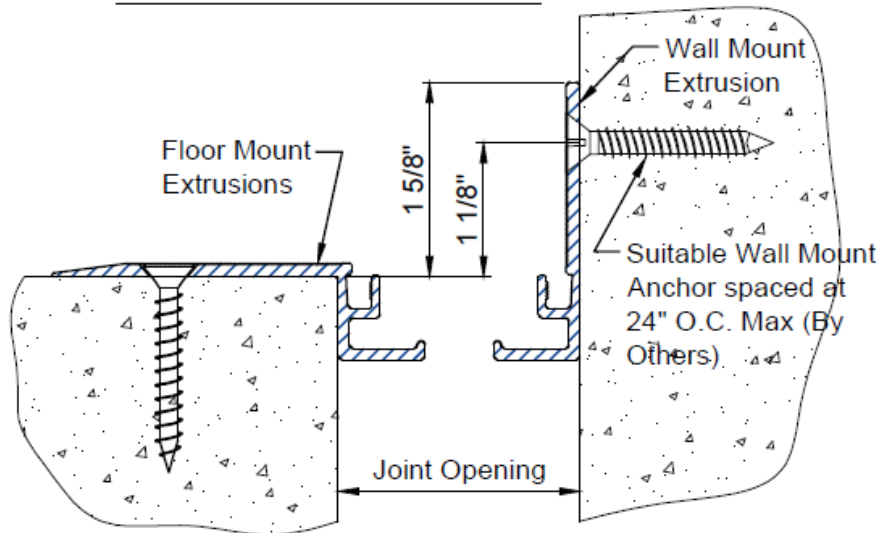

- 4** (CWFS-200/C and CWFS-300/C Conditions Only)  
Snap on Elastomeric Seal to the Center Support Plate before installation into the Base and/or Wall Mount extrusions.

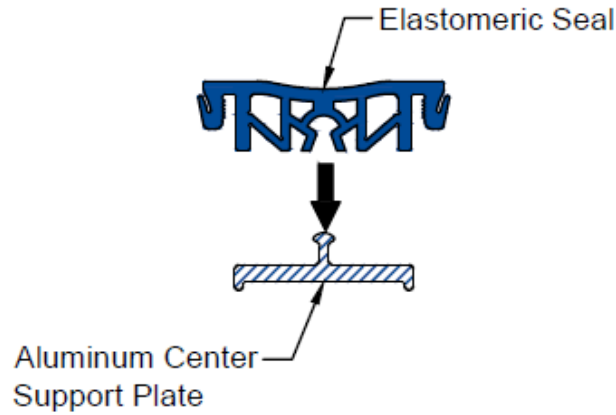

- 5** (CWFS-200/C and CWFS-300/C Conditions Only)  
Insert Elastomeric Seal/Support Plate Assembly into the slots of the Aluminum Base Extrusion, exercising care not to damage Elastomeric Seal.

**Note:** If possible, please stagger the splices on the support plate and base members by at least 12".

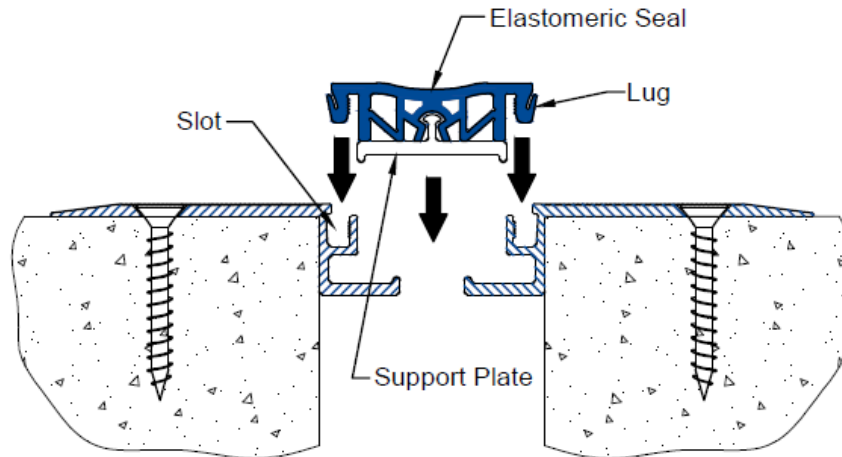

## Suggested Field Splice Procedure

1. Cut ends of seal with a sharp knife and miter box to the desired angle. Ensure that cuts are clean and straight.
2. Clean ends of seal with a solvent.
3. Brush apply PP Primer to both seal ends to be joined.
4. Apply 241F Adhesive to one of the two seal ends to be bonded.
5. Apply pressure, bringing the two surfaces into tight contact immediately after adhesive is applied. Hold in place for one to two minutes for initial bond.
6. Re-check quality of all splices/miters and apply adhesive as required.
7. It is usually recommended to allow 15 minutes prior to installing seal. To achieve proper working strength, care shall be exercised since it takes 24 hours for adhesive to fully cure.



241F Adhesive



PP Primer

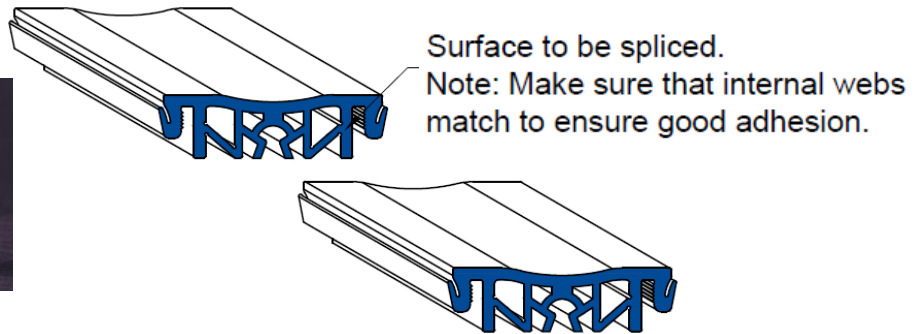

*Follow us on social media for industry news, new product announcements & more:*

