

Installation Procedure

Watson Bowman Acme Corp. 95 Pineview Drive Amherst, NY 14228
phone: (716) 691-7566 fax: (716) 691-9239
website: www.wbacorp.com

Information provided herein, including but not limited to, any drawing, design, photograph, graphic, or statement(s) ("Materials") are proprietary and the property of Watson Bowman Acme Corporation ("Company"). Reproduction, translation, or reduction to any electronic medium or machine readable form, in whole or part, is strictly prohibited, except for the express purpose for which it has been furnished, without prior written consent of Company. All Materials contained herein are provided by Company for information purposes only. Company reserves the right to amend or withdraw any information contained in the Materials without notice. All technical or other advice by Company, whether verbal or written, concerning products, or the use of products in specific situations ("Advice") is given by Company and is used at the Users own risk.

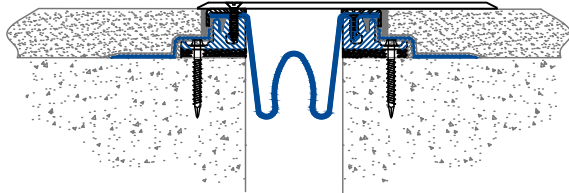

J:\MARKETING\Website-Product Info\WaboWater Title\images\wt800.250\image6.jpg

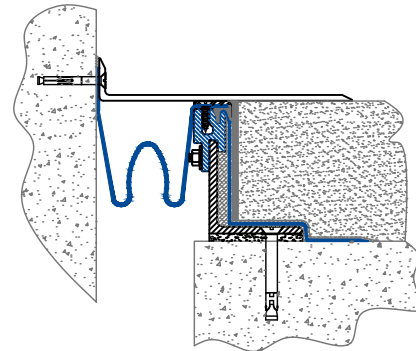
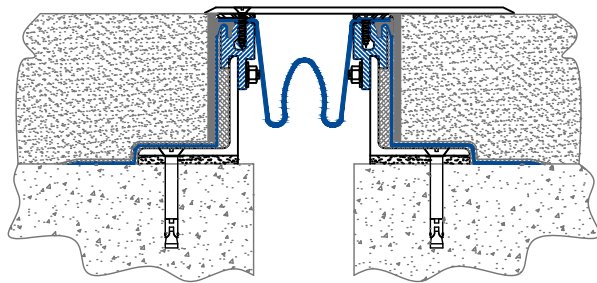

Wabo® Watertite - Traffic Series Model(s) "WT-800/150 thru WT-800/450" Horizontal Expansion Control Systems

The following installation procedure is very important and must be fully understood prior to beginning any work. To ensure proper installation and performance of expansion joint system the following actions must be completed by the installing contractor. Failure to do so will affect product warranty.

- 1) Carefully read and understand installation procedure. Contact WBA's Technical Service Department at (800) 677-4922 for product assistance.
- 2) Inspect all shipments and materials for missing or damaged components and hardware. Contact Customer Service at (800) 677-4922 with WBA's order number and invoice for prompt assistance.
- 3) Inspect substrate or adjacent construction for acceptance before beginning work. Report unacceptable construction to the project manager to schedule repair work.
- 4) Review WBA shop drawings for project specific detailed information if Engineering services were purchased at time of order.

Standard Components For Floor Condition

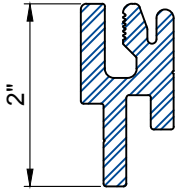

Aluminum Receiver
P/n: 8203

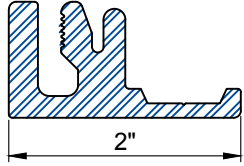

Aluminum Low Height Receiver
P/n: 8205
(For WT-X/150 Series)

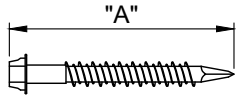

Tapcon Concrete Anchor
(Refer to chart below for size and part number)

1/4" dia Washer
P/n: 7473

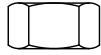

1/4" Dia nut
P/n: 7869

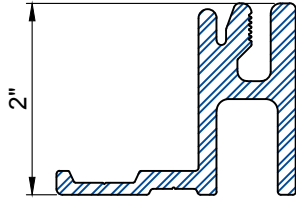

Aluminum Base Member
P/n: 8217
(For WT-X/250 Series)

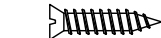

1/4" X 3/4" Screw
P/n: 5738

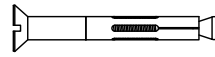

1/4" X 3.0" Concrete Expansion Anchor
P/n: 6582 *

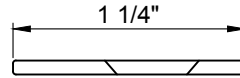

Corner Retainer Cap
P/n: 8211 *

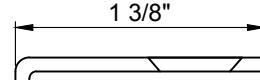

Retainer Cap
P/n: 8210

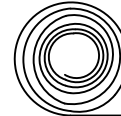

(Option) Flashing Sheet
P/n: 3164



1/4" X 1" Bolt
P/n: 4836

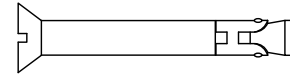

3/8" X 3" Kwik Bolt Concrete Anchor
P/n: 6593
(For WT-X/350 & 450 Series)

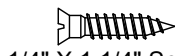

1/4" X 1 1/4" Screw
P/n: 5514
(For WT-800 Series Coverplate)

Model	P/N	"A"
WT-800/150	6523	1 3/4"
WT-800/250	6524	2 1/4"

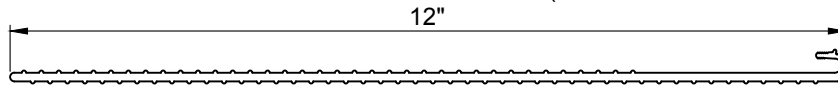

PVC Flashing Sheet
P/n: 8216B

Components shown below vary in size depending on model of system

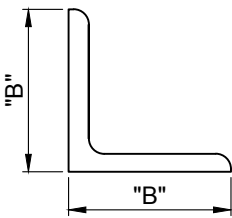

Base Angle

(Refer to Chart below for size and P/n)
Corner Conditions use same size angles

Model	P/N	"B"
WT-800/350	8207	2"
WT-800/450	8206	3"

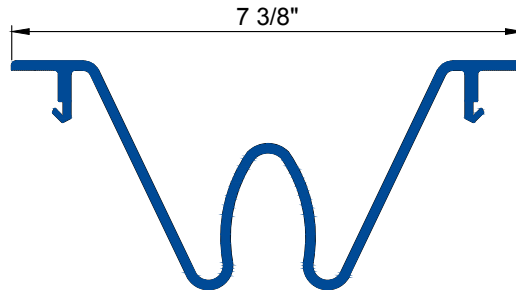

WT-800 Elastomeric Seal
P/n: 8215



3/16" Stainless Steel Corner Coverplate
P/N: 8219
(For WT-800/150,250,350,450 Corner Series)

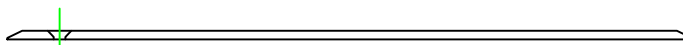

3/16" Stainless Steel Coverplate
P/N: 8218
(For WT-800/150,250,350,450 Series)

Watson Bowman Acme Corp.
95 Pineview Drive Amherst, NY 14228
phone: (716) 691-7566 fax: (716) 691-9239
website: www.wbacorp.com

Installation procedure: Watertite WT system
Watson Bowman Acme Corp. reserves the right to amend or withdraw any information contained herein without notice and will not be responsible for any inaccuracy or ambiguity of any information contained herein.

Installation Procedure

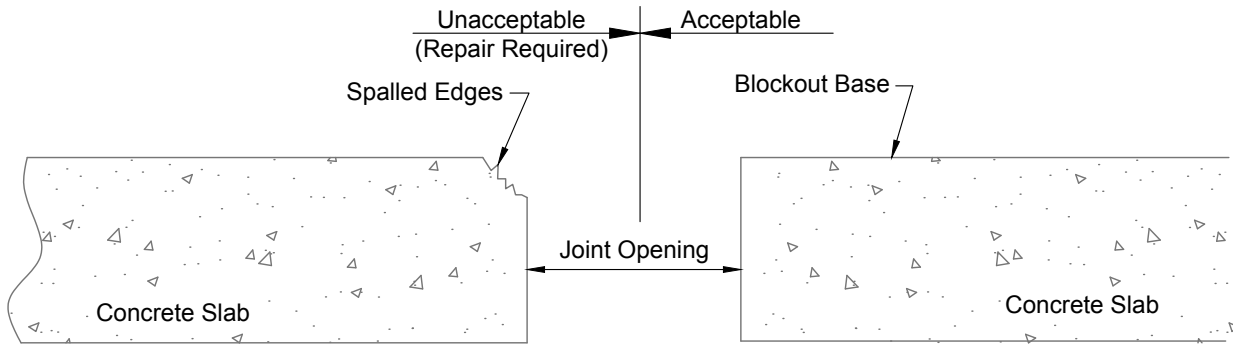

1 Prepare concrete blockout for installation of Wabo®WaterTite Expansion Control System. Deficiencies in blockout base and spalled edges must be corrected prior to beginning work.
Note: UTILIZING Wabo®Renew, repair corner of concrete slab following manufacturers written instructions. Request Procedure # WBA 4030 or download from WBA's Website.

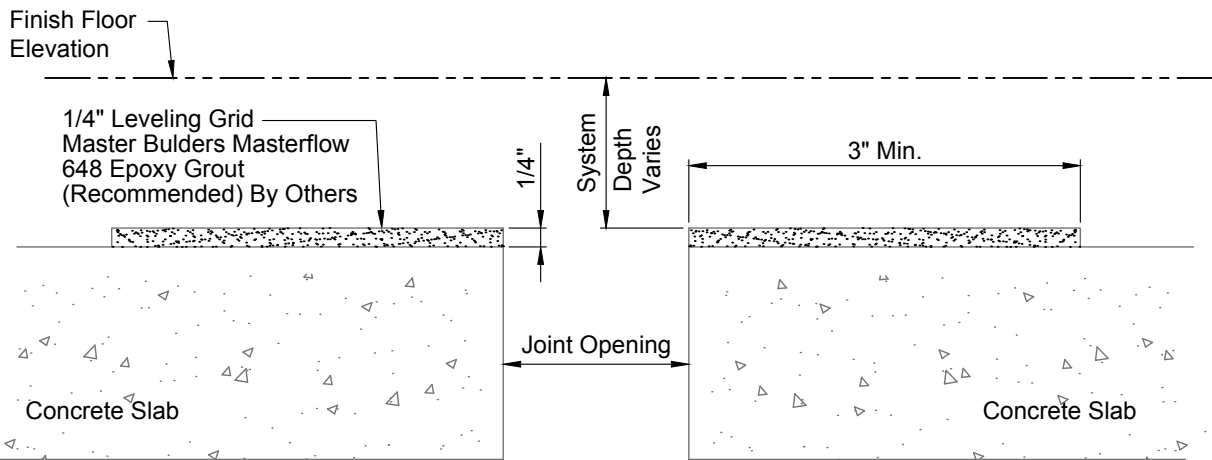

2 Prepare concrete blockout for installation of expansion joint. Variations in block out dimensions must be corrected prior to beginning work.
Note: Manufacturer recommends using Master Builders Masterflow 648 Epoxy Grout, 1/4" min thickness to ensure that there is level surface to install expansion control system.

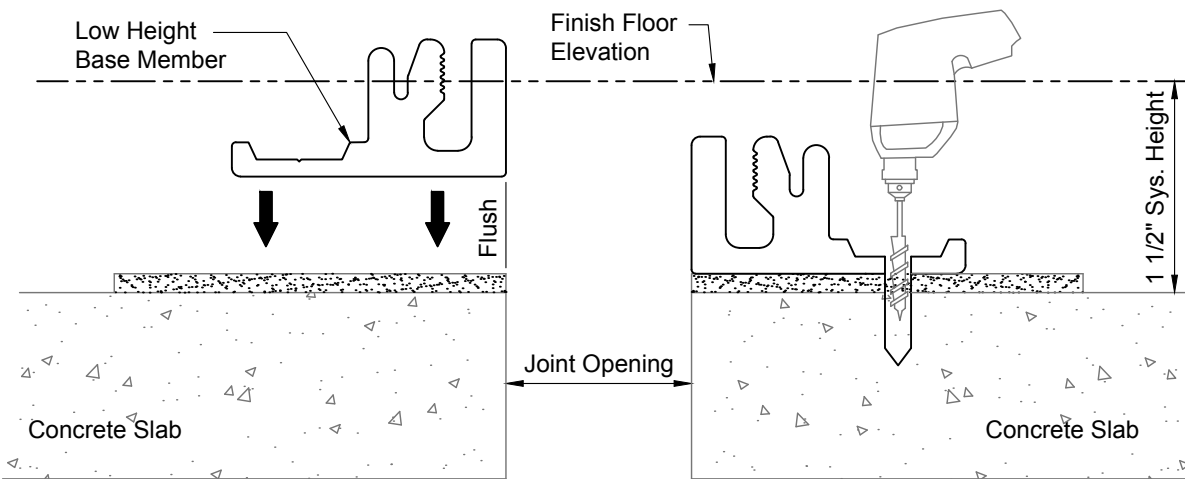

WT800/150

3 Position Low height base member on blockout so that the low height base member is flush with edge of opening. Use low height base member as a template. With it's position fixed, drill hole for 1/4" x 1-3/4" Tapcon anchor to proper depth. Blow out holes and utilize a Shop-Vac or other similar equipment to ensure that all debris is removed from the anchor hole locations.

Note:
Follow Manufacturer's Recommendations for proper Anchor Installation.

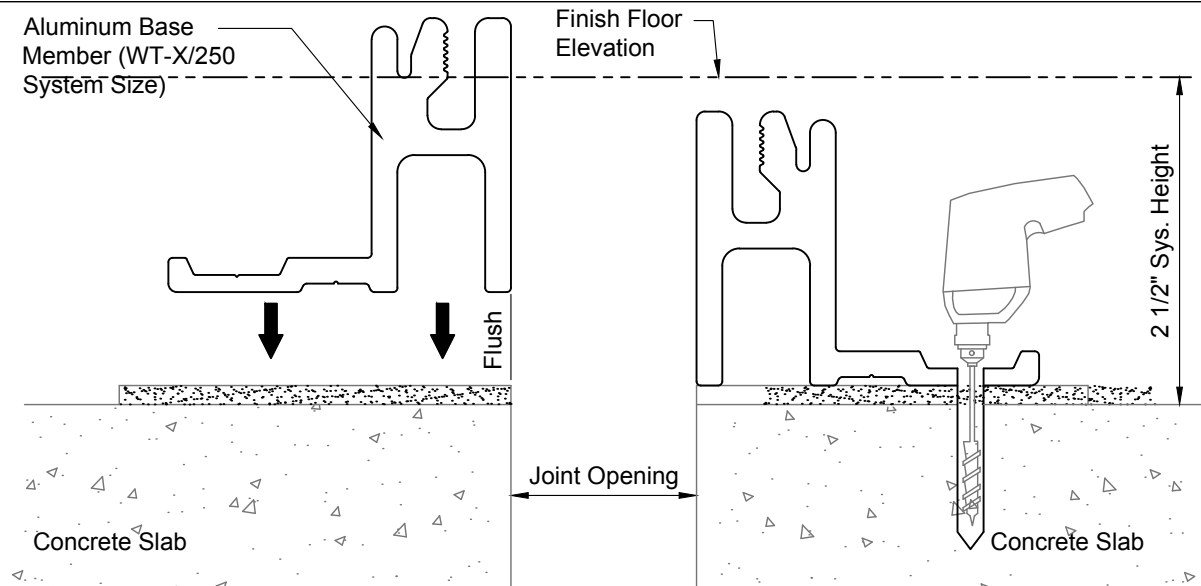

WT800/250

3A Position Aluminum Base member on blockout so that the base member is flush with edge of opening. Use Aluminum base member as a template. With it's position fixed, drill hole for 1/4" x 2-1/4" Tapcon anchor to proper depth. Blow out holes and utilize a Shop-Vac or other similar equipment to ensure that all debris is removed from the anchor hole locations.

Note:
 Follow Manufacturer's Recommendations for proper Anchor Installation.

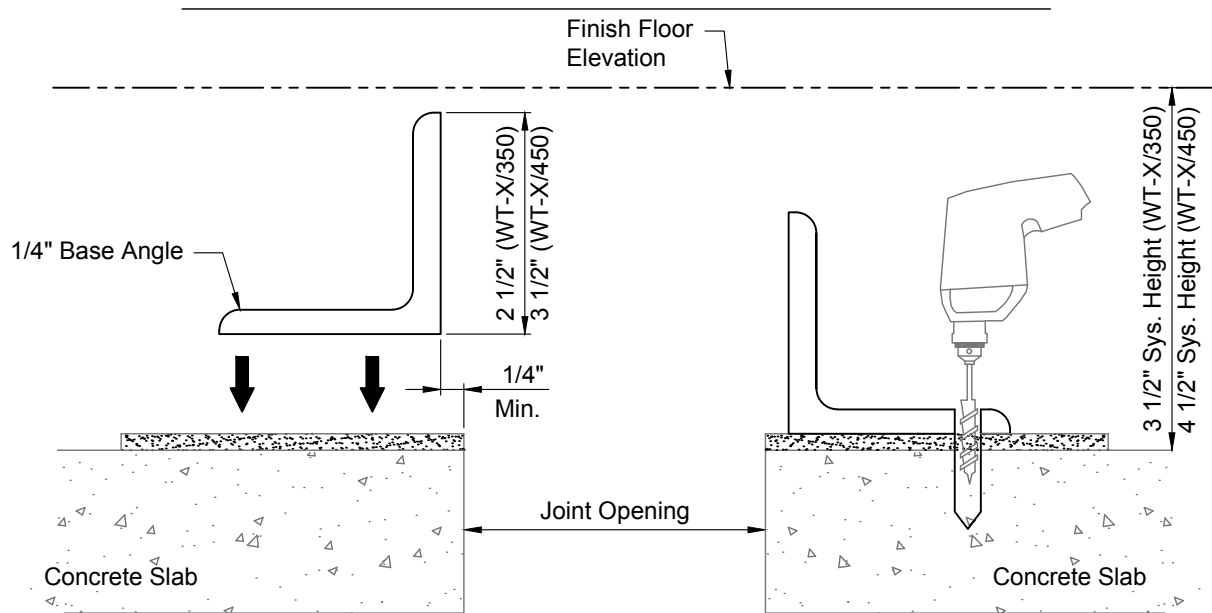

WT800/350 & WT800/450

3B Position 1/4" base Angle on blockout so that base angle is recessed 1/4" from edge of opening. Use 1/4" Base angle as a template to drill anchor locations in concrete slab. With it's position fixed, drill hole for 3/8" x 3" Kwik Bolt Concrete anchor to proper depth. Blow out holes and utilize a Shop-Vac or other similar equipment to ensure that all debris is removed from the anchor hole locations.

Note:
 Follow Manufacturer's Recommendations for proper Anchor Installation.

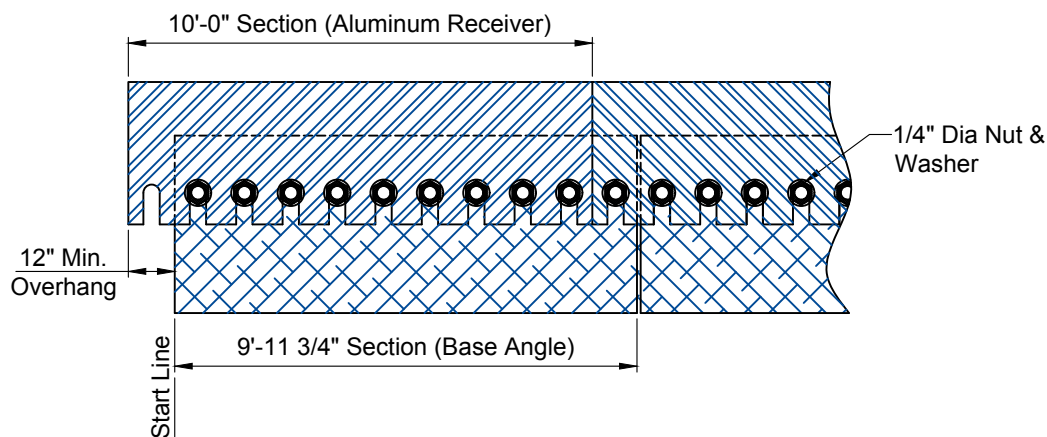
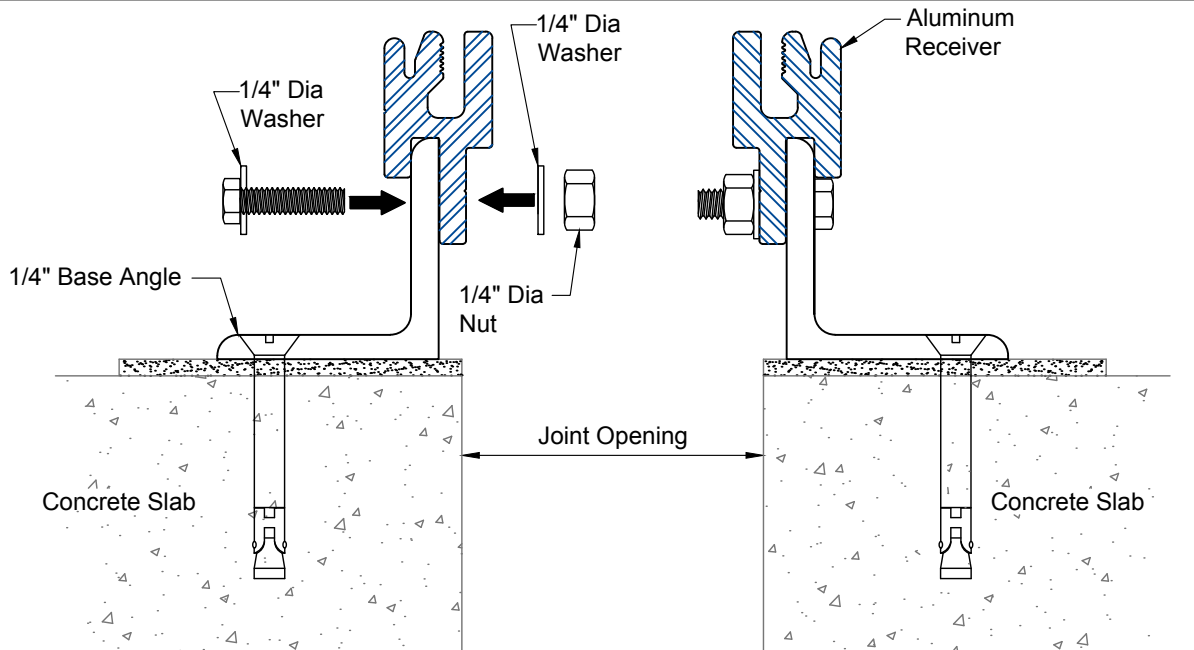

4

Insert 1/4" x 1" lg bolt into slots provided in the steel angle to ensure proper fit of the aluminum extrusion on the steel angle. Once Aluminum extrusion has been placed on the steel angles, make sure that there is a 12" Min overhang between the aluminum receiver and the base angle. This is to ensure that the splice lines will be staggered. Using a permanent marker draw a line in the aluminum receiver where the excess aluminum receiver shall be cut. Once aluminum receiver has been cut, line up aluminum receiver slots with the 1/4" bolt on the base angle. Utilizing the 1/4" Dia washer on each side of the angle and nut fasten the receiver to the base angle. When securing the receiver to the base angle, ensure each nut and washer is tightened securely to the base angle.

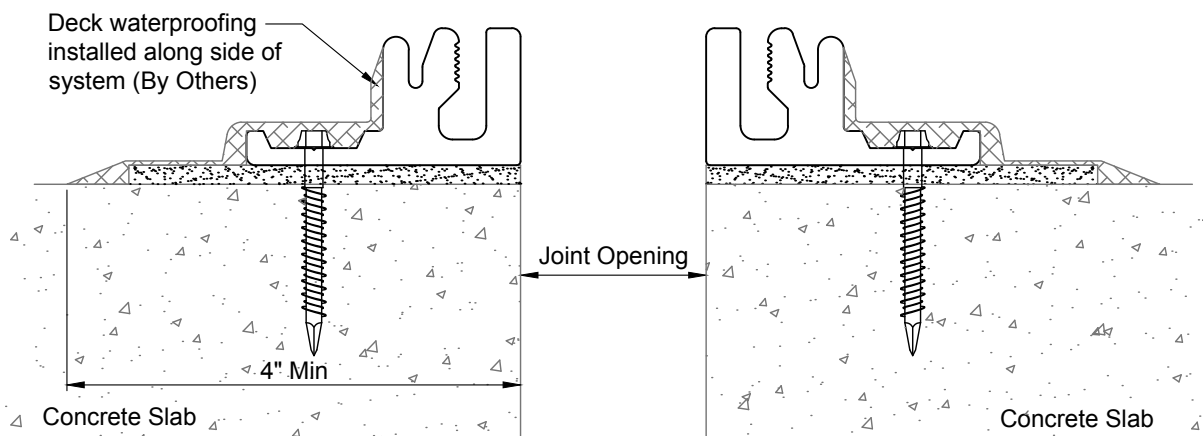

5

Install deck waterproofing material along the concrete slab and side of the aluminum extrusion. **Caution:** Contact Deck Waterproofing Manufacturer to discuss product application and procedure for proper installation.

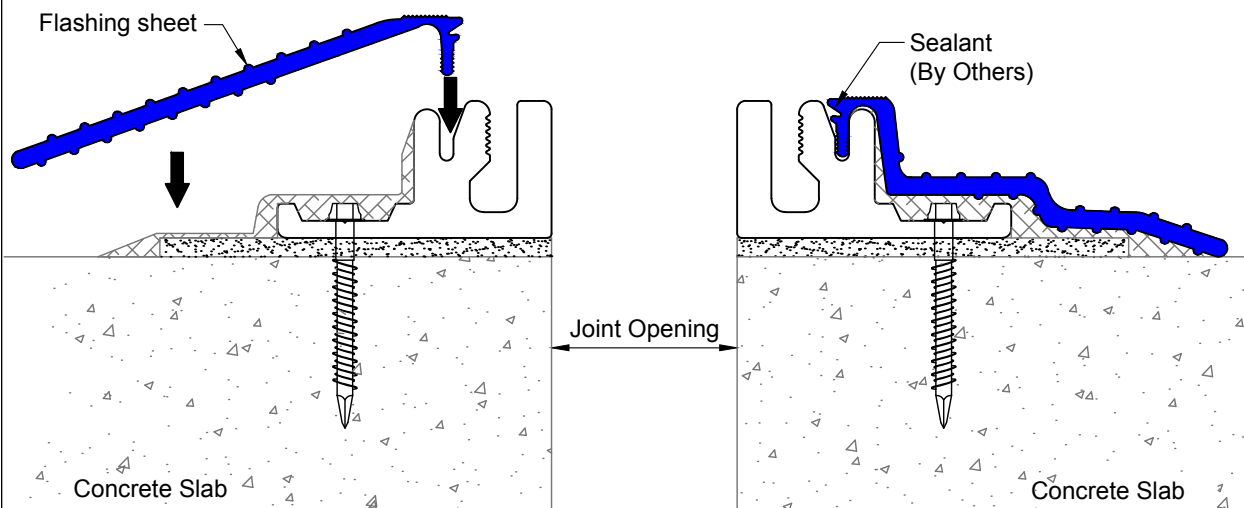

6

Once first layer of deck waterproofing material has been installed, the Flashing sheet may be installed. Push in edge of flashing sheet into the cavity of the aluminum receiver as shown above. Once the edge of the flashing sheet has been inserted into the cavity, let the remaining flashing sheet lie on top of the deck waterproofing material. (Optional - When using Optional flashing sheet or other manufacture's flashing sheet, apply a bead of sealant along top edge of flashing sheet and aluminum extrusion to ensure a watertight finish.)

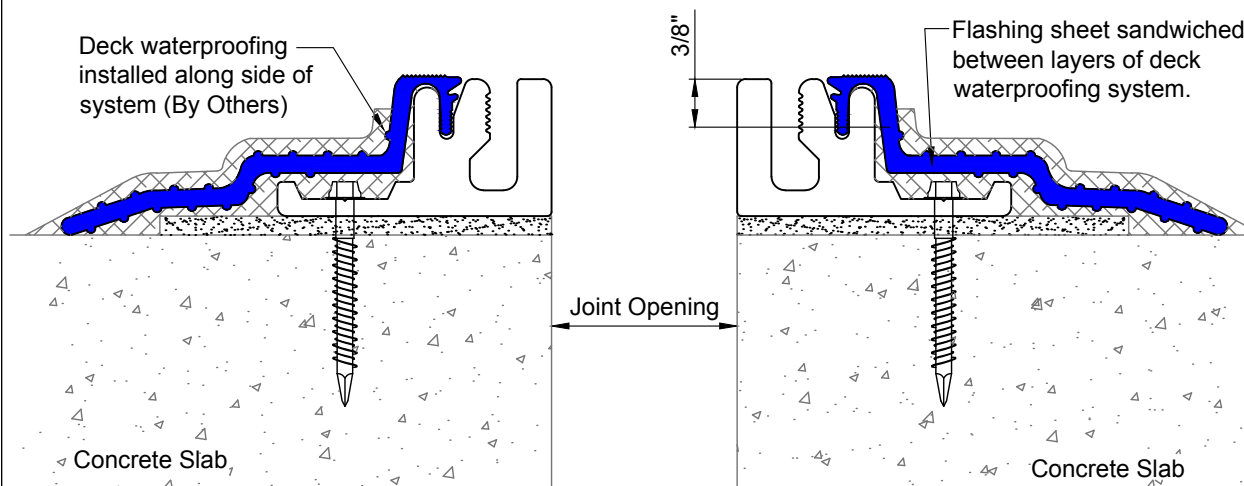

7

Once flashing has been installed, a second layer of deck waterproofing material can be installed over the flashing sheet to sandwich along the concrete slab and side of the aluminum extrusion. **Caution:** Contact Deck Waterproofing Manufacturer to discuss product application and procedure for proper installation.

Installation procedure: Watertite WT system

Watson Bowman Acme Corp. reserves the right to amend or withdraw any information contained herein without notice and will not be responsible for any inaccuracy or ambiguity of any information contained herein.

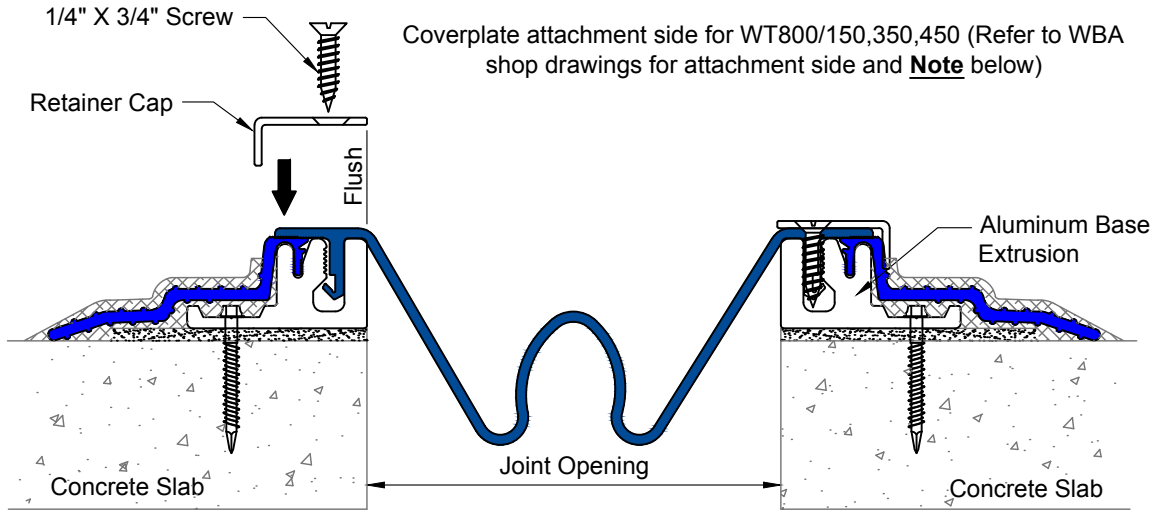

WT800/150,350,450

8A

Position retainer cap so that it lays flat on the top side of the seal flap as shown above. Then push the side of the retainer cap so that the edge of the cap butts up flush with the edge of the base extrusion. Utilizing the 1/4"x3/4" Lg screws provided, fasten retainer cap at predrilled locations. When installing the screws for the retainer cap make sure that they are flush with the top of the cap.

Note: When installing retainer cap, one side of the expansion system retainer cap will use the 1/4" x 1 1/4" lg screw provided. After the finished surface is installed in the following step, the 1/4" x 1 1/4" lg screws will be removed and re-used for attaching coverplate to base extrusion.

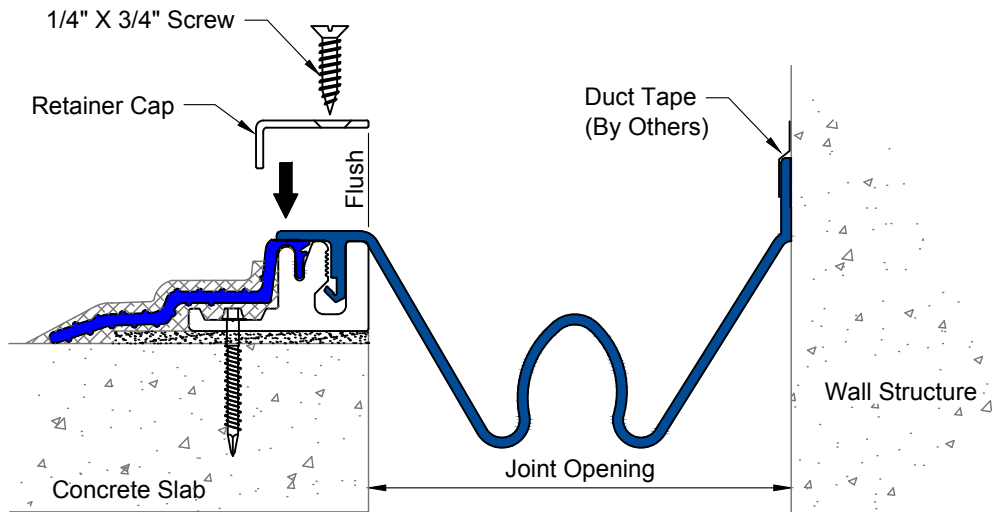

WT800/150C,350C,450C

8B

Position retainer cap so that it lays flat on the top side of the seal flap as shown above. Then push the side of the retainer cap so that the edge of the cap butts up flush with the edge of the base extrusion. Utilizing the 1/4"x3/4" Lg screws provided, fasten retainer cap at predrilled locations. When installing the screws for the retainer cap make sure that they are flush with the top of the cap.

Note: Utilizing duct tape (By Others) for temporary fastening of seal to wall structure before corner coverplate is installed.

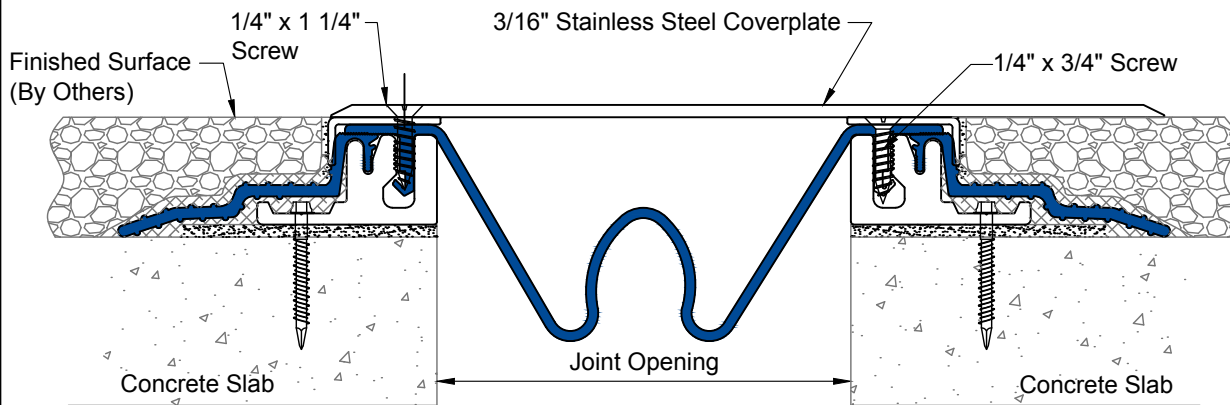

WT800/150,350,450

9A

Prior to installing the 3/16" thk coverplate, remove 1/4" x 1 1/4" lg screws from the retainer cap. **Do Not** discard screws, they will be reused to fasten coverplate. Once screws have been removed, align pre-drilled holes in coverplate with the holes of the retainer cap. Once holes are aligned, utilizing 1/4" x 1 1/4" lg screws fasten coverplate to aluminum base extrusion.

Note: When installing the screws for the coverplate make sure that they are flush with the top of the coverplate so that it does not pose as a tripping hazard.

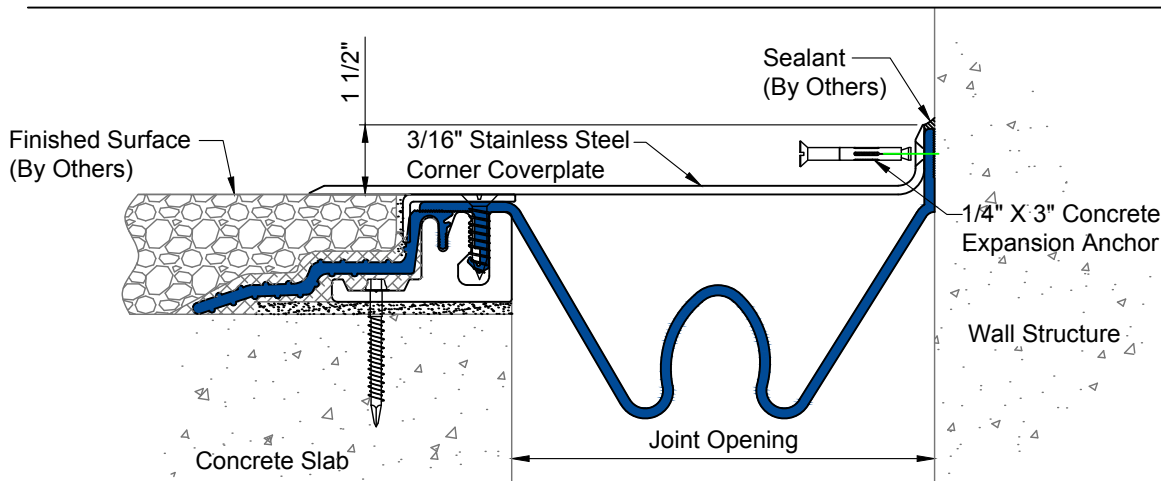

WT800/150C,350C,450C

9B

Align 3/16" thk corner coverplate with wall structure, making sure that the elastomeric seal will be supported by the corner coverplate. Once corner coverplate is in position, fasten the corner coverplate utilizing the 1/4" x 3" lg concrete expansion anchor at the pre-drilled locations. Follow Manufacturer's Recommendations for proper Anchor Installation.

After corner coverplate has been fastened to wall structure, remove duct tape from elastomeric seal flap to apply a bead of polyurethane sealant (By Others) along top edge of coverplate as shown.

Installation procedure: Watertite WT system

Watson Bowman Acme Corp. reserves the right to amend or withdraw any information contained herein without notice and will not be responsible for any inaccuracy or ambiguity of any information contained herein.

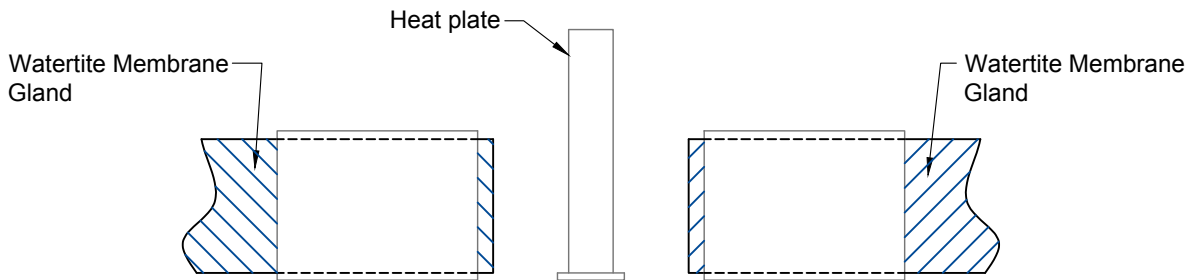

10

Recommended Method:

- Using a miter box and back saw with no teeth cut seal ends square.
- Preheat heat plate to 425°, Approximately 5 minutes.
- Insert seal into gland molds leaving 1/2" overhang off one end of the mold. Slowly move seal face to touch the heat plate. Leave the gland touching the heat plate for about 1-2 minutes or until material edge starts rolling back (Melting).
- Remove seals from heat plate, align webs and outside face of seals together. Once edges have been aligned apply enough pressure to cause the ends of the glands to slightly protrude upwards. Allow approximately 3 to 4 minutes of cure time prior to releasing pressure.

Secondary method:

- Using a miter box and back saw with not teeth cut seal ends square.
- Clean ends of seal and apply PP Primer. Allow PP Primer to dry for 2 minutes before applying 241F adhesive.
- Apply 241F Adhesive to one side only and hold seals together for 45 seconds. Let cure for 2-3 minutes. (For best results, bond small portions of the seal at a time)
- Splice will reach full strength in 24 hours.

Touch Up:

Using soldering gun with a flat tip, run along the splice to make any touch ups. Careful not to burn any holes in the seal.



241F Adhesive
 (P/n: 2716)



Heat Plate



PP Primer
 (P/n: 2717)